



GUMMI

Type AN
Pneumatic
Couplings





Gummi has more than 50 years' experience in the field of industrial mechanical transmission, and plays an active role in different and important local and international industrial markets. It offers a wide range of elastic, pneumatic and hydraulic couplings, as well as clutches and industrial pneumatic brakes, both standardized and special.

Gummi is synonymous with Quality and Service, these two features being our most precious paradigm. All products are manufactured according to ISO 9001 International Standards, certified since 1999.

Our continuous and innovative development in our product line -added to the technical advice provided by our engineering department, which always aims at practical use - has allowed us to set the cornerstone of our achievements in unparalleled technical assistance.

Our long experience and modern design systems with advanced production equipment turn our **Gummi** products into key high-tech parts, necessary in any first-class transmission system



Our **Gummi** products' use versatility has allowed them to be satisfactorily assembled, with various types of uses within the metallurgical, iron and steel, mining, oil and naval industries, among others. They have also been successfully mounted with a host of special and specific uses in power transmissions.



Gummi is not just a GOOD PRODUCT: it is QUALITY, RELIABILITY, SAFETY AND PEACE OF MIND.





Contents

General characteristics

Other possibilities of Gummi AN couplings

Gummi AN constructive characteristics

Method of selection

Dimensions and assembly

The Gummi pneumatic coupling has been specifically designed to protect the driving and driven machinery for the adverse and destructive effects of high torque fluctuations and torsional movements that are associated with reciprocating pumps, combustions, engines, compressors, mills, as well as various applications in the marine industry.

Benefits of the Gummi AN pneumatic coupling

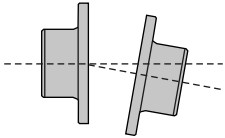

Misalignments absorption

Due to the flexibility of the rubber pneumatic chamber, it can accommodate radial, angular and axial misalignments.

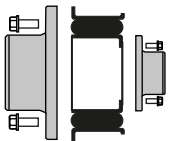

Simple installation

Because of the concentration of its components, it facilitates the alignment and the assembly, it is not necessary the use of special tools.



Noise Insulator

It notably aids to reduce the transfer of noises from one machine to the next.

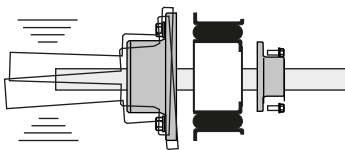

Dampens vibrations and shocks

It acts as a shock reducer, and a vibration dampener taking advantage of the natural resilience of the rubber pneumatic chamber.

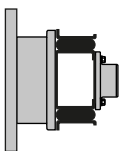

Different & versatile models

There are 13 combinations of the AN Coupling assembly that can be made with a standard element, as well as the dual (tandem) design, and the floating shaft design.



No lubrication necessary

Because of its constructive characteristics, no lubrication is required.



Assured quality

Manufactured under the strict Quality System, and produced using only the highest quality raw materials.

Technical Information: Available through our official distributors and Internet Sites:

gummiargentina.com

With flywheel adapter:

This design simplifies the installation onto a flywheel of an industrial engine, and also allows for a simplified removal of the coupling without disturbing any of the equipment.

The Gummi AN coupling consists of a solid and split adapter ring which are directly bolted to the engine flywheel. The outer rim of the AN Coupling is bolted to the split adapter ring and the inner rim to the coupling hub on the driven shaft.

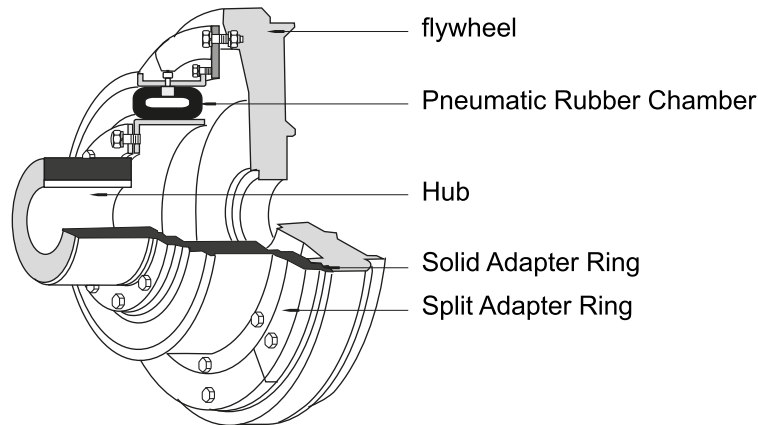

Dual (tandem) design:

The main characteristic of the Gummi AN coupling with this configuration, is that it can be made with twice the deflection and one half the rigidity of a single AN coupling.

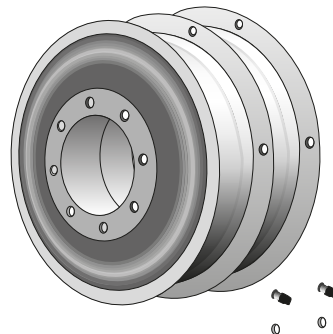

Floating shafts:

This is formed by the combination of 2 standard Gummi AN couplings and an intermediate floating shaft. This combination takes advantage of the basic self-centering traits of the gland assembly, and allows for a reasonable angular misalignment of the connection shaft.

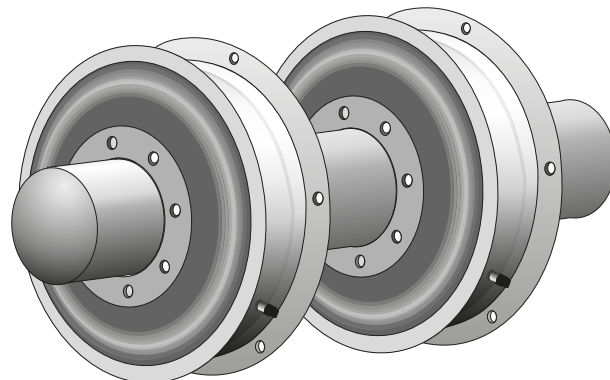



The special resilient rubber pneumatic chamber is treated in order to prevent losses of air pressure and is made up of a combination of dense layers of rubber and durable nylon cords. The steel inner and outer rims are bonded to the rubber chamber. The chamber and also be bolted directly to a flange on the connected equipment, or even to the shaft using the adapter plate and hub.

The sizing of the Gummi AN coupling depends on the load that is going to be transmitted, and the power and speed at which it must operate. As soon as the power and the speed have been established, determine the kind of load according to the following procedure:

A - Determine the factor of service fs

- 1a- Use table 1, for engines of electronic equipment, which involve moderate and constant load.
- 2a- For applications of motive equipment, thermal or turbines use **fs** of table 2, with fluctuating load.
- 3a- For equipment, engines and machinery not included in this classification consult to the factory for its recommendation.

B - Determine the "K" factor.

- 1b- From table 3 and knowing the **rpm**, you can determine the k factor that takes part in the basic calculation of capacity.

C - Calculate the basic CB capacity

- 1c- Basic capacity

D - Selection of the size of the AN coupling

- 1d- It will be determine the size in table 4, according to the CB value, equal or greater as the calculated one.

E - Verify maximum of speed.

- Verify in table 4, maximum of speed for each size; consult to the factory if the wished speeds are in excess of those.

F - Determine the configuration.

- Select the best assembly option between the 13 standard versions. Pay a particular attention to the maximum diameter that can place the hubs.

TABLE 1

SERVICE FACTORS (For General Applications)		
BLOWERS		
Centrifugal.	1.50	
Lobe or Vane.	2.00	
CAR DUMPERS	1.50	
CAR PULLERS	2.50	
COMPRESSORS.		
Centrifugal.	1.50	
Rotary, Lobe, Vane	2.00	
Reciprocating:		
1 cylinder, single effect.	6.00	
1 cylinder, double effect.	5.00	
2 cylinders, single effect.	5.00	
2 cylinders, double effect.	4.00	
4 or more cylinders, single effect.	3.50	
3 or more cylinders, double effect.	3.00	
CONVEYORS		
Apron, Assembly, Belt, Chain,		
Lift, Screw	1.00	
Bucket	1.25	
Live Roll, Shaker and Reciprocating	3.00	
CRANE AND HOISTS.		
Main Hoist.	2.50	
Skip Hoist.	3.00	
Slope.	2.50	
Bridge, Travel or Trolley	2.20	
CRUSHERS		
Ore	3.00	
Mineral or stones	3.50	
DYNAMOMETER. VENTILATORS.	1.50	
Centrifugal.	1.50	
Cooling Tower.	3.00	
Forced.	2.50	
Induced.	3.00	
Large (Industrial, mining, etc).	2.50	
FEEDERS		
Apron, Belt, Disc, Screw	2.20	
Reciprocating	2.50	
GENERATORS.		
Uniform Even load.	1.50	
Crane, Hoist or Railway Service.	2.20	
Welder Load	3.00	
HAMMER MILLS	2.50	
(High yield crushing)		
TOOLS MACHINES.		
Auxiliaries and Traverse Drives	1.50	
Bending Roll	2.50	
Main drive.	2.00	
Notching Press	2.50	
Punching Press, Planer, Plate	2.50	
Reversing	1.50	
METAL FORMING MACHINES		
Draw Bench Carriage & Main Drive	3.00	
Extruder	3.00	
Forming Machine.	2.50	
Silters.	2.50	
Wire stretch machine and flatten machine.	3.00	
Wire Winders	2.50	
MILLS (rotating).		
Bags to stones direct or to:	3.00	
LS shaft of Reducer.	3.00	
HS shaft of Reducer.	2.50	
Dryer and cooler.	2.50	
Bar and tube direct or to:	3.50	
LS reducing axis.	3.50	
HS reducing axis.	3.00	
Tumbling Mill or Barrel	2.50	
MIXERS.		
Concrete (continuous).	2.50	
Concrete (intermittent).	2.20	
Sledgehammer crushing machine type Simpson.	2.00	
PULVERIZERS		
Hammer Mill (high yield)	2.50	
Wood crushing machine	3.00	
Rollers	2.00	
PUMPS.		
Centrifugal	1.50	
Constant Speed	2.50	
Gear or Rotary	2.00	
Reciprocating:		
1 cylinder, single or double action.	3.00	
2 cylinders, single action.	3.00	
2 cylinders, double action.	2.50	
3 or more cylinders.	2.50	

MACHINES SERVICE FACTORS

TABLE 1

SERVICE FACTORS (For General Applications)

CLAY WORKING INDUSTRIES.

Brick-Press, Briquette Machine.	
Pug Mill. Clay Working Machine	2.50

DREDGES.

Cable Reel .	2.50
Conveyors.	2.00
Jig Drive.	3.00
Cutter.	3.00
Maneuvering Winch.	2.50
Pumps (uniform load).	2.50
Screen Drive, Stackers.	2.50
Utility Winch.	2.50
Service freight elevator.	2.20

SIFTER , SCREENS

Air Washing	1.50
Rotary Coal or Sand	2.00
Vibrating	3.50
Water	1.50

LUMBER

Band Resaw	2.00
Circular Resaw, Cut Off	2.50
Head Rig, Edger	
Wood Crusher	3.00
Log Haul Transport	3.00
Mechanical brush	2.50
Rollers, non-reversing	2.0
Reversing Rolls	3.0
Sawdust Conveyor	1.8
Slab Conveyor	2.5
Sorting Table	2.0

OIL and PETROCHEM INDUSTRY.

Cooler/ Chiller.	1.80
Oilwell Pumping.	3.00
(do not surpass 150% of maximum torque).	
Paraffin Filter Press.	2.00

PAPER FACTORIES.

Barker, Auxiliary, Hydraulic	3.00
Barker, Mechanical	3.00
Barking Drum	3.50
Pulp and Beater	2.50
Bleachers	4.00
Log Haul	3.00
Pulp grinder	3.00
Supplier	2.00
Stock, Chest Washer, Thickener.	2.20

RUBBER INDUSTRY

Mixing Mill	3.50
Calendar	3.00
Laminator	3.00
Tires Assembly machine.	3.00
Tire and Tube Press Opener of rubber and chambers (max. torque).	1.50
Tuber, Strainer, Pelletizer	2.50
Heating mill	3.00
Washer	3.50

Table 2

Engine Service Factor	
Number of Cylinders	Service Factor
1	*
2	*
3	3.5
4	3.0
5	3.0
6	2.5
7	2.0
8	2.0
9	2.0
10	
or more	1.5

Table 3

K Factor					
RPM	K	RPM	K	RPM	K
3600	.034	950	.114	380	.235
3300	.037	900	.118	340	.263
3000	.041	850	.124	320	.270
2800	.044	800	.130	300	.285
2600	.047	750	.137	280	.300
2400	.051	700	.145	260	.320
2200	.056	650	.154	240	.340
2000	.061	600	.164	220	.362
1900	.064	580	.168	200	.390
1800	.068	560	.172	180	.422
1700	.072	540	.178	160	.470
1600	.075	520	.183	140	.520
1500	.078	500	.190	130	.550
1400	.084	480	.196	120	.582
1300	.088	460	.200	100	.675
1200	.095	440	.210	60	1.000
1100	.101	420	.217	30	1.820
1000	.109	400	.225	10	4.461

Table 4

CAPACITIES, DIAMETERS AND SPEEDS					
Size	Basic capacity (BC)	Diameters		Maximum speed	
		Ø gross	Ø máx.	Standard	Special Bal.
11 AN	4.8	3/4	2 1/2	1800	3600
13 AN	6.0	7/8	1 3/4	1800	3600
15 AN	9.6	7/8	2 1/2	1800	3600
16 AN	15.0	1 1/8	2 1/2	1800	3000
18 AN	24	1 3/8	2 7/8	1800	3000
21 AN	38	1 3/4	3 1/4	1800	2400
24 AN	60	1 3/4	4 1/4	1800	2400
28 AN	96	2 1/4	5 1/4	1600	2200
33 AN	150	2 3/4	6 1/4	1200	2000
39 AN	240	2 3/4	7 1/4	1000	1750
46 AN	384	3 3/4	8 1/4	900	1500
53 AN	600	4 1/4	9 1/2	750	1250
62 AN	960	4 3/4	10 3/4	650	1000
72 AN	1500	5 3/8	12	500	850
85 AN	2400	6 3/4	13 1/4	450	750

For a speed greater than the indicated one in special balance, consult to the factory.

Examples

The following examples will illustrate a typical selection of couplings.

Requirements.

A coupling to connect an electrical engine from 50 HP to 750 RPM to a mixer (heavy service). Motive axis Ø 70.6 mm and Ø lead shafts 60 mm.

Selection

From table 1 settles down **fs** mixer = 3,5. In table 3 **k** factor for 750 RPM is of 137. Applying the formula **CB = HP x fs x K**

$$50 \times 35 \times .137 = 23,97$$

The Gummi AN coupling to use is according to table 4 the 18A.

The maximum shafts diameter that places each hub of the size 18A is of 74 mm, that satisfies the requirement of the engine as of the mixer. As the coupling will operate to 750 RPM, it will not be necessary a special balance (see table 4).

Dimensions for assembly in SAE steering wheel



ASSEMBLY 1

ASSEMBLY 2

ASSEMBLY 3

ASSEMBLY 4

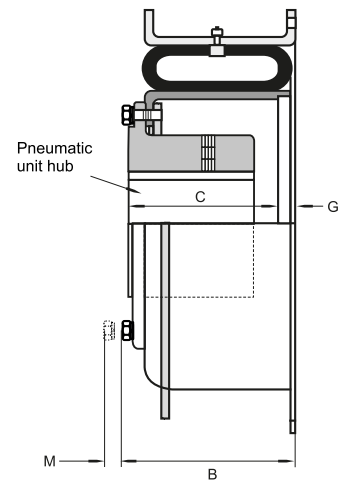
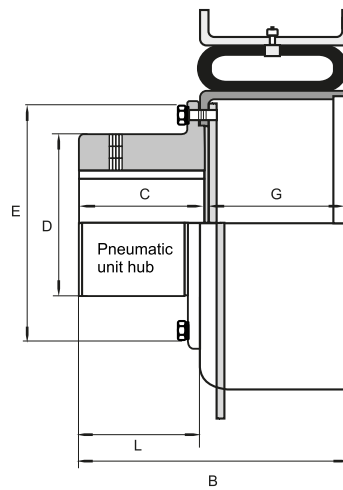
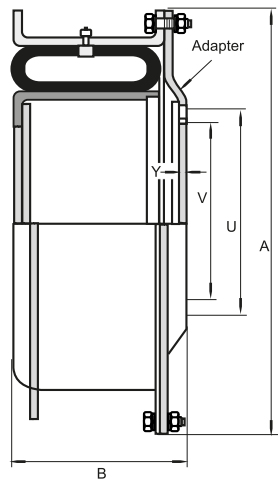
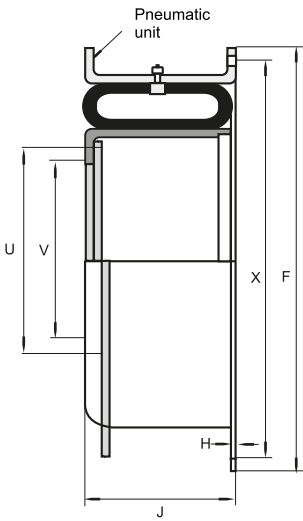

ASSEMBLY 5

ASSEMBLY 6

ASSEMBLY 9

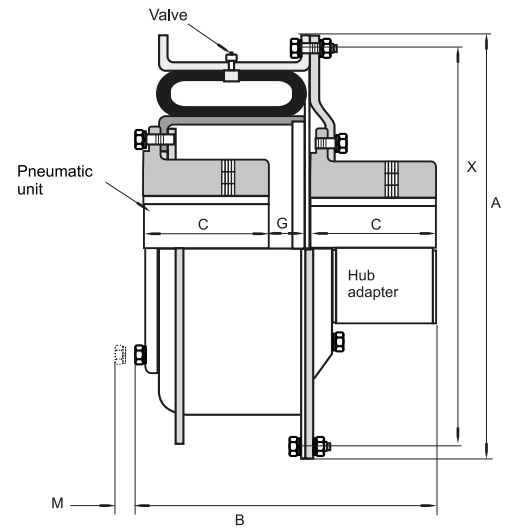
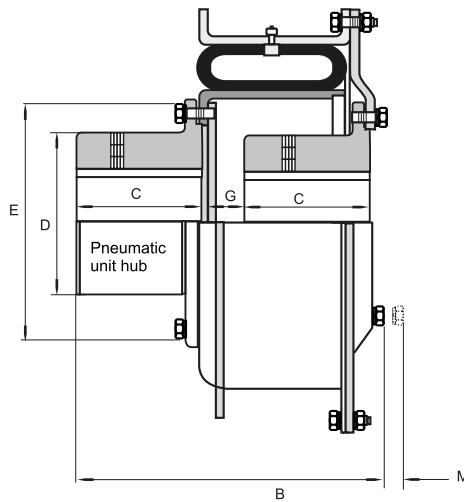
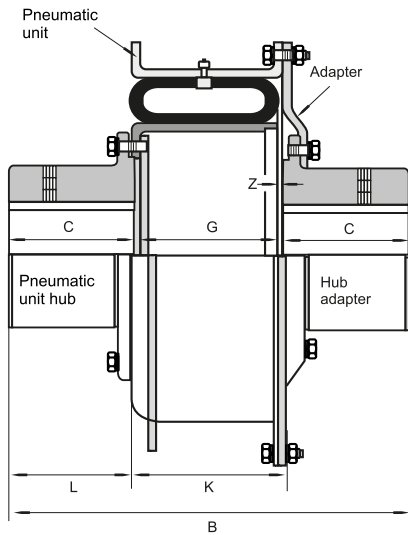

SIZE	A	Dimensions in millimeters																				
		B											C	D	E	F	G					
		Mtg. 2	Mtg. 3	Mtg. 4	Mtg. 5	Mtg. 6	Mtg. 9	Mtg. 10	Mtg. 11	Mtg. 12	Mtg. 13	Mtg. 3					Mtg. 4	Mtg. 5	Mtg. 6	Mtg. 9	Mtg. 10	
15AN	295.0	110.2	166.6	106.4	253.2	201.6	192.0	173.7	121.4	189.7	128.2	82.5	89.0	141.2	288.9	84.0	17.5	88.0	21.3	21.3	91.0	
16AN	320.5	116.5	179.3	112.7	272.2	214.3	204.7	186.4	127.7	202.4	134.6	89.0	95.0	152.4	314.3	40.4	17.5	99.9	21.3	21.3	97.5	
18AN	362.0	223.0	192.0	119.0	286.7	227.0	217.4	199.0	134.0	215.0	141.0	45.0	111.2	168.0	353.9	96.7	17.5	100.8	21.3	21.3	103.5	
21AN	398.5	132.5	201.6	127.0	307.0	246.0	233.4	208.8	146.5	230.8	156.4	101.6	130.0	200.0	390.5	100.0	17.5	103.8	21.3	21.3	107.0	
24AN	441.0	145.2	227.0	139.7	345.0	271.5	258.8	234.0	159.2	256.2	169.0	114.3	158.7	235.0	433.3	127.7	17.5	116.5	21.3	21.3	119.8	
28AN	498.0	158.0	250	154.0	391.4	304.8	292.0	261.0	174.7	288.0	187.7	133.3	200.0	285.7	490.5	120.6	9.6	124.7	13.4	13.4	127.7	
33AN	583.0	175.5	289.0	170.0	445.2	341.3	327.0	296.0	192.0	324.6	205.2	152.4	228.6	336.5	574.6	136.6	6.3	140.4	10.4	10.4	143.7	
39AN	673.0	207.2	352.5	201.6	521.4	401.5	382.5	347.0	226.5	281.7	242.8	177.8	266.7	393.7	665.1	162.0	9.6	165.8	13.4	13.4	169.1	
46AN	775.0	226.3	378.0	378.0	578.6	434.6	420.6	395.2	245.6	419.8	261.8	196.8	304.8	470.0	766.7	180.8	9.6	185.0	13.4	13.4	188.2	
53AN	888.0	273.0	439.6	263.6	574.6	522.2	498.3	450.8	297.6	496.8	320.2	228.6	349.2	533.4	876.3	221.0	17.5	217.4	23.8	23.8	222.2	
62AN	1035.0	306.3	496.8	295.0	757.0	581.0	555.7	508.0	331.0	555.7	353.5	254.0	393.7	628.6	628.6	242.8	23.8	249.0	30.2	30.2	250.0	
72AN	1187.0	347.7	552.4	334.8	839.7	650.7	627.0	566.6	378.0	620.7	407.0	273.0	438.0	723.9	1174.7	273.0	38.0	280.9	45.9	45.9	287.0	
85AN	1378.0	373.0	603.2	365.0	916.0	701.5	678.0	617.4	403.3	671.5	432.5	304.8	482.6	898.6	1365.2	298.4	38.0	306.3	45.9	45.9	312.6	

The dimensions are exclusively as reference and are subject to changes without previous warning.

ASSEMBLY 10

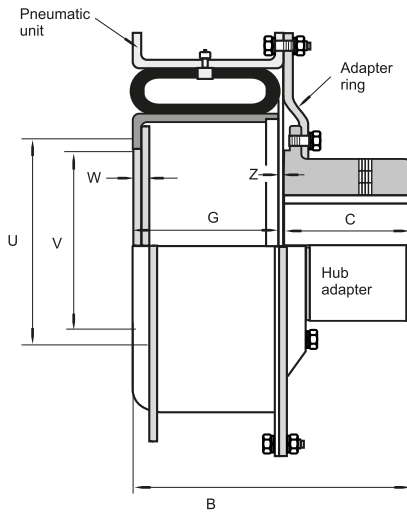

ASSEMBLY 11

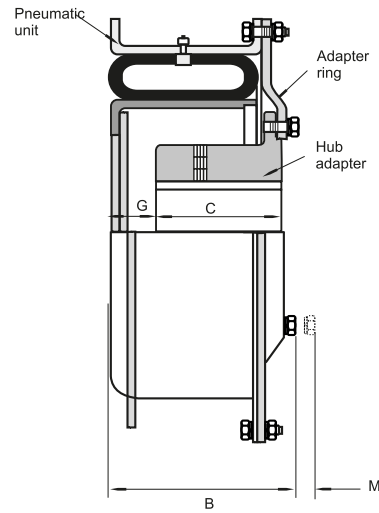

ASSEMBLY 12

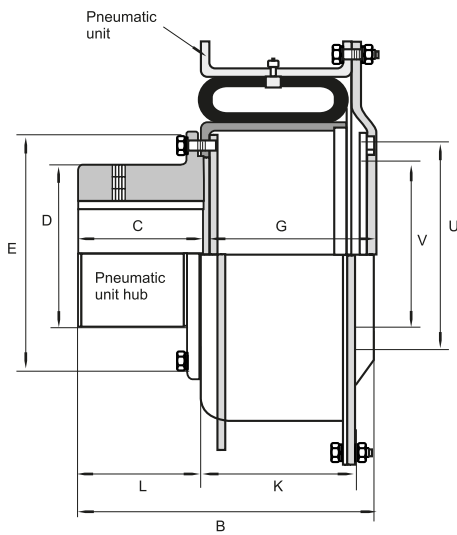

ASSEMBLY 13

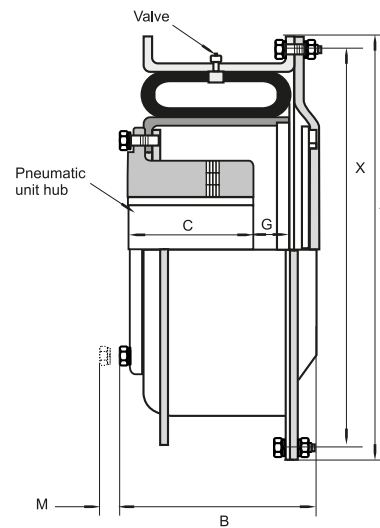

Dimensions in millimeters

G			H	J	K	L	M					U	V	W	X	Y	Z	SIZE
Mtg. 11	Mtg. 12	Mtg. 13					Mtg. 4	Mtg. 6	Mtg. 9	Mtg. 11	Mtg. 13							
24.6	107	40.3	4.3	87.3	93.7	79.2	14.2	17.5	14.2	17.5	14.2	119	93.6	10.4	268.2	6.3	4	15AN
24.6	113	40.3	4.8	93.7	100.0	85.8	14.2	17.5	14.2	17.5	14.2	130	103.2	11.2	293.6	6.3	4	16AN
24.6	119	40.3	4.8	100.0	106.0	92.0	14.2	17.5	14.2	17.5	14.2	146	119.0	11.2	327.0	6.3	4	18AN
24.6	129	46.7	4.8	103.0	111.0	98.5	17.5	19.0	17.5	19.0	17.5	171	139.7	13.4	363.0	9.6	4	21AN
24.6	142	46.7	4.8	115.8	124.0	111.2	17.5	19.0	17.5	19.0	17.5	203	166.2	13.4	406.4	9.6	4	24AN
16.7	154	43.6	4.8	124.0	133.0	130.0	20.5	23.8	20.5	23.8	20.5	250	209.5	15.7	463.5	11.0	4	28AN
13.4	172	42.2	6.3	139.7	149.0	149.0	20.5	23.8	20.5	23.8	20.5	298	244.4	15.7	541.0	12.7	4	33AN
16.7	204	51.5	6.3	165.0	178.0	174.0	22.3	23.8	22.3	23.8	22.3	349	292.0	19.0	633.0	15.7	4	39AN
17.2	223	51.5	7.8	184.0	197.0	193.0	22.3	23.8	22.3	23.8	22.3	422	362.0	19.0	733.5	15.7	4	46AN
28.4	268	74.6	15.7	216.0	235.0	223.0	33.2	30.0	33.2	30.0	33.2	482	422.0	28.0	831.8	20.5	6	53AN
35.0	301	82.5	15.7	247.0	266.0	249.0	33.2	30.0	33.2	30.0	33.2	571	504.0	28.0	971.5	22.3	6	62AN
52.3	341	106.4	15.7	279.0	301.0	273.0	38.0	33.2	38.0	33.2	38.0	654	571.0	30.0	1117.6	22.3	8	72AN
52.3	366	106.4	22.3	304.8	327.0	293.0	38.0	33.2	38.0	33.2	38.0	825	762.0	35.0	1305.0	22.3	8	85AN

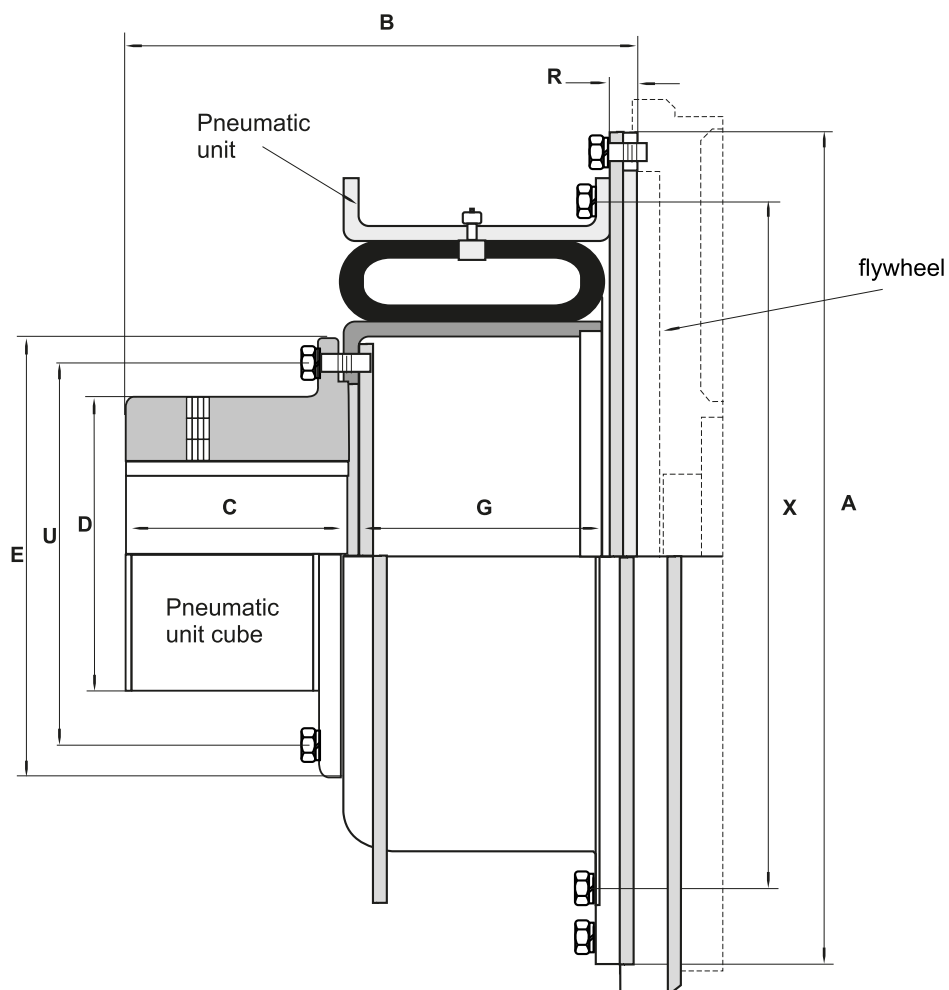

Dimensions in millimeters												
flywheel SAE		Coupling Size	Weight s/ a	A	B	C	D	E	G	R	U	X
Clutch in inches	Ø E/c a...											
11.5	333.3	16AN	21	360.1	201.6	89	95	152	90.4	25.4	130.0	293.6
14	438.1	21AN	38	475.0	227.0	101	130	200	100.0	28.4	171.4	363.4
16	188.9	24AN	52	525.7	252.4	114	158	235	112.7	28.4	203.2	406.4
18	542.9	28AN	77	579.6	279.4	133	200	285	120.6	28.4	250.9	463.5
21	641.3	33AN	120	681.2	343.4	152	228	336	136.6	32.0	298.4	541.2
24	692.1	33AN	132	741.6	343.4	152	228	336	136.6	32.0	298.4	541.2

* For another kind of steering wheel, consult to factory.

The dimensions are exclusively as reference and are subject to changes without previous warning.

How to request the Gummi AN pneumatic coupling

The following information is necessary to measure a Gummi pneumatic coupling correctly.

1- Connection size.

- a) Nominal power and conductor maxim (hp, Kw, CV)
- b) Conductor speed (rpm)
- c) Kind of impelling machine (electrical engine, turbine, combustion engine), include number of cylinders.
- d) Daily time of service, frequency of starting.
- e) Kind of impelling machine (reciprocal, oscillating movement), indicate number of cylinders.

2- Shafts diameters.

- a) Consult in factory.

3- Configuration.

- a) Kind of assembly: in the standard version are available 13 different configurations, if you need another kind, consult in factory.

NOTE:

All the size of the Gummi AN pneumatic coupling are provided pressurized with fluid to 100 psi and sealed from factory. Once started it is recommended to control the pressure after an initial period of work.



SAUVE S.A.

Gdor. Ugarte 2682 (C.P. 1636)
Olivos -Buenos Aires - Argentina

Sales Department

Phone: (+54 11) 4760-7938
intl.sales@gummiargentina.com

www.gummiargentina.com

