



GUMMI

Type A Flexible Couplings





Gummi has more than 50 years' experience in the field of industrial mechanical transmission, and plays an active role in different and important local and international industrial markets. It offers a wide range of elastic, pneumatic and hydraulic couplings, as well as clutches and industrial pneumatic brakes, both standardized and special.

Gummi is synonymous with Quality and Service, these two features being our most precious paradigm. All products are manufactured according to ISO 9001 International Standards, certified since 1999.

Our continuous and innovative development in our product line -added to the technical advice provided by our engineering department, which always aims at practical use - has allowed us to set the cornerstone of our achievements in unparalleled technical assistance.

Our long experience and modern design systems with advanced production equipment turn our **Gummi** products into key high-tech parts, necessary in any first-class transmission system



Our **Gummi** products' use versatility has allowed them to be satisfactorily assembled, with various types of uses within the metallurgical, iron and steel, mining, oil and naval industries, among others. They have also been successfully mounted with a host of special and specific uses in power transmissions.



Gummi is not just a GOOD PRODUCT: it is QUALITY, RELIABILITY, SAFETY AND PEACE OF MIND.



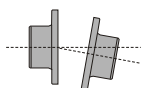

Misalignment Solutions Misalignment is a major reason for failure in bearings, as well as the other components of the motor (gears, gaskets, seals) which were not originally designed to absorb stresses caused by misalignment. The Gummi flexible coupling is the ideal solution to this issue, since its primary features are elasticity, misalignment compensation and shock absorption.

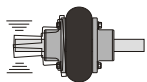

Vibration and Shock Load Dampening

The flexible couplings ability to absorb torsional vibrations and shock loads provides for an extended working life of the machine and or equipment. The amount of vibrations is reduced by approximately 70% when a flexible coupling is installed properly.

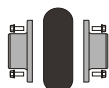

Simple Installation

The replacement is simpler and faster because it is comprised of only one rubber element. Using smaller alignment tolerances allows the element to extend the working life of its flexible coupling. It is not necessary to move the parts in order to replace the flexible element.



Symmetry - Security - Balance

Since the rubber element utilized in the Gummi flexible coupling is one single element with integrated mounting flanges, it is guaranteed to be balanced and free from safety or security issues and concerns.



Different models

- Back-Pull-Out - Diesel engines - Axial displacements - Shafts with different diameters - Floating shafts - Torque limiters - Security locking - Conical Shafts - Space Limited Areas



No need to Lubricate

As a result of its design and constructive characteristics, the element does not require lubrication.



Economy

The working life capacity in the applications spare parts increases, reducing costly down time, minimizing the cost of replacement components, lubricants and inventory. The flexible element of the coupling works for a prolonged period of time without needing to be replaced.



Assured quality

Manufactured under the strict Quality System, and produced using only the highest quality raw materials.

When ordering the **Gummi** Flexible Coupling, the following information must be provided.

Example: Flexible coupling model A-105 with two integral hubs and 1 spacer L= 250 mm.

We recommend that you read all instructions before beginning the assembly or installation of our couplings. (see page 8)



1- MODEL

According to the selection (Tables I and III)

2- TYPE OF HUB

Advise the selected type of hub
Without indication - Two conventional hubs

- CN** Conventional hub
- CI** Integral hub
- CX** Axial hub
- EC** Conventional hub for point of conical shafts
- ECI** Integral hub for point of conic shafts

3- TYPE OF ASSEMBLY

- EF** Floating shafts
- ES** Spacer

- 1- Model**
- 2- Type of Hub**
- 3- Type of Assembly**
- 4- Additional Information**

- LT** Torque limiting
- BS** Security ties
- RE** Special covering
- DF** Disk brakes
- CIN** Invert hub
- APF** Pulley brakes
- CE** Reel
- CF** Bridle plate
- CC** Fitted hubs

4- ADDITIONAL INFORMATION

Dimension required

Technical Information: Available through our official distributors and Internet Sites:

gummiargentina.com

Data required to select appropriate coupling:

- Power in Kw.
- R.P.M.
- Shaft diameters.
- Service Factor (Table II).

Quick selection:

multiply the Kw by the Service Factor

Once the value is obtained from the formula, go to Table I below, and read down on the rpm column until the rpm for the case engine is found. Read across until the closest bigger number or equivalent, to result obtained from the formula is found. Then read up to the top of the chart to find the recommended coupling. Verify on the Table III the diameter of each shaft in relation of its maximum and minimum.

Table I - Max. Temp. 80°C

MODEL	A 20	A 25	A 30	A 35	A 45	A 50	A 60	A 70	A 80	A 90	A 95	A 105	A 120	A 140	A 155	A 165	A 170	A 200	A 240	A 300	A 350	A 400	
100	0.37	0.60	0.82	1.19	2.16	4.48	6.64	12.16	16.79	22.39	25.02	32.69	52.24	89.55	101.49	126.86	154.85	265.90	455.22	910.45	1254.70	1783.58	
200	0.75	1.19	1.72	2.31	4.18	8.96	13.06	25.22	32.69	44.78	50.37	66.27	104.48	180.07	202.98	253.73	308.81	532.69	910.45	1820.00	2510.30	3566.27	
300	1.19	1.79	2.61	3.58	6.34	13.06	19.63	37.31	49.48	67.16	75.60	98.88	156.72	269.63	304.48	381.34	463.66	798.51	1365.67	2730.45	3764.93	5349.85	
400	1.57	2.31	3.43	4.78	8.43	17.76	26.12	49.48	65.30	89.55	100.75	132.46	208.96	359.18	406.07	508.95	618.51	1064.40	1820.00	3640.90	5019.53	7133.43	
500	1.94	2.99	4.33	5.97	10.30	22.39	32.69	62.54	82.09	11.94	125.97	165.15	261.19	448.73	507.46	635.82	772.39	1331.19	2275.22	4550.37	6274.25	8917.01	
600	2.31	3.59	5.15	7.09	13.06	27.09	39.18	74.63	97.99	134.33	150.22	197.76	313.43	539.18	609.70	762.68	927.24	1597.01	2730.45	5460.82	7529.85	10699.63	
700	2.84	4.18	5.97	8.28	14.93	31.72	46.64	86.79	114.79	157.69	175.37	231.34	365.67	628.73	711.19	889.55	1082.09	1862.91	3185.67	6371.27	8784.55	12483.21	
720	2.91	4.33	6.19	8.58	15.37	32.69	47.61	89.55	117.54	161.42	180.97	237.91	375.97	646.49	731.34	914.92	1112.91	2129.70	3276.12	6553.21	9035.45	12839.55	
800	3.21	4.78	6.94	9.33	16.79	36.42	53.21	98.88	130.60	180.07	200.60	264.03	417.01	718.28	813.43	1017.16	1236.04	2262.16	3640.90	7280.82	10039.18	14266.79	
850	3.36	5.07	7.31	10.30	17.76	38.28	55.97	105.45	139.03	191.27	213.66	280.82	443.13	763.06	864.17	1080.59	1313.43	2395.52	3868.51	7736.04	10667.01	15158.58	
900	3.58	5.30	7.76	10.90	18.66	40.15	59.70	111.94	147.39	202.46	225.75	297.61	469.25	808.81	914.17	1144.02	1390.90	2661.42	4096.12	8191.27	11294.78	16049.49	
1000	3.96	5.97	8.58	12.16	21.49	44.78	66.27	124.10	164.18	224.85	250.97	330.22	521.49	898.36	1015.67	1270.89	1545.75	2928.21	4550.37				
1100	4.40	6.57	9.33	13.06	23.36	49.48	72.76	136.19	180.07	247.24	276.12	362.91	573.73	987.91	1117.16	1398.50	1700.60	3060.67	5005.60				
1150	4.55	6.79	10.30	14.03	24.25	51.34	75.60	142.76	188.43	259.43	288.28	379.70	599.85	1032.69	1167.91	1461.90	1777.09	3194.03					
1200	4.78	7.09	10.75	14.63	25.22	54.10	79.33	149.25	196.87	269.63	301.24	396.49	625.97	1078.36	1218.65	1525.37	1854.48	3385.30					
1300	5.15	7.76	11.19	15.90	27.09	58.81	85.82	161.42	212.69	292.01	326.49	429.10	678.21	1167.91	1320.89	1652.23	2009.33	3385.30					
1400	5.52	8.28	12.16	16.79	29.85	62.54	92.39	173.51	229.48	314.40	351.72	462.69	730.45	1257.46	1422.38	1779.85	2164.18	3726.72					
1500	5.97	8.96	13.06	17.76	31.72	67.16	98.88	186.57	245.37	336.79	376.87	495.37	782.69	1347.54	1523.88	1906.71							
1600	6.34	9.33	14.03	18.66	33.58	71.87	105.45	198.73	262.16	359.18	401.12	527.99	834.93	1527.09									
1700	6.72	10.30	14.93	20.52	36.42	76.49	111.94	210.82	278.96	381.57	426.34	561.57	887.16										
1750	6.94	10.60	15.37	21.04	37.31	78.36	115.67	217.39	286.42	392.76	439.40	578.36											
1800	7.09	10.90	15.90	21.49	38.28	81.19	118.51	223.88	294.78	403.96	451.49	594.25											
2000	7.91	12.16	16.79	23.36	42.41	89.55	132.46	248.13	327.46	448.73	501.87	660.45											
2250	8.96	13.06	16.93	27.09	47.61	100.75	148.36	279.85	368.51	498.13	564.40	743.51											
2500	10.30	14.93	21.49	29.85	53.21	111.94	165.15	310.67	409.55	561.57	627.84	825.60											
2750	11.19	16.79	23.26	32.69	57.84	123.13	181.94	341.42	450.60	617.54	690.30	907.69											
3000	12.16	17.76	26.12	35.45	63.43	134.33	197.76	372.24	491.64	673.51	904.85												
3250	13.06	19.63	27.99	38.28	69.03	145.52	214.55	403.96															
3500	14.03	20.52	29.85	42.01	73.73	157.69	231.34	434.70															
3600	14.40	21.49	30.12	42.91	76.49	161.42																	
3750	14.93	22.39	32.69	44.78	79.33	168.88																	
4000	15.90	23.36	34.55	47.61																			
4500	17.76	27.09	38.28	53.21																			
5000	19.55	29.85	42.91	59.70																			

Nominal K.W.
All the reading between that fall below the heavy black line correspond to Flexible Couplings models with hubs that are fitted on the flanges (CE).

For velocity lower than 100 rpm see BR catalogue

Engine drive service factor :

In case that engine has four or more cylinders, must be added 1,0 to the Service Factor selected in table II. For engines with more than 6 cylinders add 0,5 to the Service Factor selected in table II. For engines with less than 4 cylinders contact Gummi.

Table II

GENERAL INDUSTRY

AGITATORS			GENERATORS		Hog	2.00
Vertical and Horizontal		Flight, Screw	Even Load	1.00	Roller	1.50
Screw Propeller, Paddle	1.00	Bucket	Hoist or Railway Service	1.50	PUMPS	
GARGE HAUL PULLER	2.00	Live Roll, Shaker and	Welder Load	2.00	Centrifugal	
BLOWERS		Reciprocating	HAMMERMILL	1.75	Constant speed	1.00
Centrifugal	1.00	CRANES AND HOIST	LAUNDRY WASHER OR TUMBLER	2.00	Frequent speed changers under load	1.25
Lobe or Vane	1.25	Main Hoist	LINE SHAFTS		Descaling, with accumulators	1.50
CAR DUMPERS	2.50	Skip Hoist	Any Processing Machinery	1.50	Gear, Rotary, or Vane	1.50
CAR PULLERS	1.50	Slope	MACHINE TOOLS		Reciprocating	
CLARIFIER OR CLASSIFIER	1.00	Bridge, Travel or Trolley	Auxiliary Drive	1.00	1 cylinder, single acting	2.50
COMPRESSORS		DYNAMOMETER ELEVATORS	Bending Roll, Notching Press,		1 cylinder, double acting	2.00
Centrifugal	1.00	Bucket, Centrifugal Discharge	Punch Press, Planer, Plate Reversing	1.75	2 cylinders, single acting	2.00
Rotary, Lobe or Vane	2.00	Freight	Main Drive	1.50	2 cylinders, double acting	1.75
Rotary, Screw	1.75	Gravity Discharge	Traverse Drive	1.00	3 or more cylinders	1.50
Reciprocating		Passenger	MAN LIFTS	▲	SCREENS	
Direct Connected	Refer to factory	ESCALATORS	METAL FORMING MACHINES		Air Washing	1.00
Without Flywheels	Refer to factory	EXCITER, GENERATOR	Draw Branch Carriage and Main Drive	2.00	Grizzly	2.00
* With Flywheel and Gear		EXTRUDER, PLASTIC	Extruder	2.00	Rotary Coal or Sand	1.50
between Compressor		FANS	Forming Machine and Forming Mills	2.00	Vibrating	2.50
and Prime Mover		Centrifugal	Slitters	1.00	Water	1.00
1 cylinder, single acting	4.00	Cooling Tower	Wire Drawing or Flattening	2.00	STEERING GEAR	1.00
1 cylinder, double acting	3.50	Forced Draft - Across the Line start	Wire Winder	1.50	STOKER	1.00
2 cylinders, single acting	3.50	Forced Draft Motor	Corfers and Uncorlers	1.50	TUMBLING BARREL	1.75
2 cylinders, double acting	3.00	Driven thru fluid or electric slip clutch	MIXERS (see Agitators)		WINCH, MANEUVERING	
3 cylinder, single acting	3.00	Gas Recirculating	Concrete	1.75	Dredge, Marine	1.50
3 cylinder, double acting	2.00	Inuced Draft with damper	Muller	1.50	WINDLASS	1.50
4 cylinders, single acting	1.75	control or blade cleaner	PRESS, PRINTIN	1.50	WOODWORKING MACHINERY	1.00
4 cylinders, double acting	1.75	Indiced Draft without controls	PUG MILL	1.75		
CONVEYORS		FEEDERS	PULVERIZERS			
Apron, Assembly, Belt, Chain		Apron, Belt, Disc, Screw	Hammermill	1.75		
		Reprocatng				

APPLICATION BY INDUSTRY

AGGREGATE PROCESSING,	(Reciprocating)	Refer to Factory	Kickout	2.00	Pulp Grinder	2.00
CEMENT, MINING KILNS, TUBE,	Log Haul	2.00	Piercer	3.00	Reel, Rwinder, Winder	1.50
ROD AND BALL MILLS	Planer	1.75	Reeler	2.50	Stock Chest, Washer, Thickener	1.50
Director or on L.S. shaft of	Rolls, Non-Reversing	1.50	Thrust Black	2.50	Suction Roll	1.75
Reducer, with final drive:	Rolls, Reversing	2.00	Tube Conveyor Rolls	2.00	RUBBER INDUSTRY	
Machined Spur Gears	Sawdust Conveyor	1.25	Sideguards	2.00	Calender	2.00
Single Helical or Herringbone Gears	Slab Conveyor	1.75	Skelp Mills	Refer to factory	Craker, Plasticator	2.50
Conveyors, Feeders, Screens,	Sorting Table	1.50	Slitters, Steel Mill only	1.75	Extruder	1.75
Elevators	Trimmer	1.75	Soaking Pit Cover Drives		Intensive or Banbury Mixer	2.50
Crushers, Ore or Stone	METAL ROLLING MILL AUXILIARIES		Lift	1.50	Mixing Mill, Refiner or Sheeter	
Dryer, Rotary	Coilers (up or down) Cold Mills only	1.50	Travel	2.50	One or two in line	2.50
Grizzly	Coilers (up or down) Hot Mills only	2.00	Straighteners	2.00	Three or four in line	2.00
Hammermill or Hog	Coke Plants		Unscramblers (Billet Bundle Busters)	2.00	Five or more in line	1.75
Tumbling Mill or Barrel	Door Opener	2.00	Wire Drawing Machinery	2.00	Tire Building Machine	2.50
BREWING AND DISTILLING	Pusher or Larry Car		OIL INDUSTRY		Tire & Tube Press Opener (Peak Torque)	1.00
Bottle and Can Filling Machines	Traction Drive	3.50	Chiller	1.25	Tuber, Strainer, Pelletizer	1.75
Brew Kettle	Pusher Ram Drive	2.50	Oilwell Pumping (not over 150% peak torque)	2.00	Warming Mill	
Cookers, Continuous Duty	Cold Mills		Paraffin Filter Press	1.50	One or two Mills in line	2.00
Lauter Tub	Strip Mills	Refer to factory	Rotary Kiln	2.00	Three or more Mills in line	1.75
Mash Tub	Temper	Refer to factory	PAPAR MILLS		Washer	2.50
Scale Hopper, Frequent Peaks	Cooling Beds	1.50	Barker Auxiliary, Hydraulic	2.25	SEWAGE DISPOSAL EQUIPMENT	
CLAY WORKING INDUSTRY	Drawbench	2.00	Barker, Mechanical	2.25	Bar Screen, Chemical Feeders,	
Brick Press, Briquette Machine,	Feed Rolls - Blooming Mill	3.50	Barking Drum		Collectors, Dewatering	
Clay Working Machine, Pug Mill	Furnace Pushers	2.00	L.S. shaft of reducer with		Screen, Grit Collector	1.00
DREGES	Hot and Cold Saws	2.00	final drive - Helical		SUGAR INDUSTRY	
Cable Reel	Hot Mills		or Herringbone Gear	2.00	Cane Carrier & Leveler	1.75
Conveyors	Edger Drivers	Refer to factory	Machined Spur Gear	2.50	Cane Knife & Crusher	2.00
Cutter Head, Jig Drive	Reversing Blooming or		Cast Tooth Spur Gear	3.00	Mill Stands, Turbine Driven	
Maneuvering Winch	Slabbing Mills	Refer to factory	Beater & Piler	1.75	with all helical or herringbone gears	1.50
Pumps (uniform load)	Strip or Sheet Mills	Refer to factory	Bleachers, Coaters	1.00	Electric Drive or Steam Engine	
Screen Drive, Stackler	Ingot Cars	2.50	Calender & Super Calender	2.00	Drive with Helical Herringbone,	
Utility Winch	Manipulators	3.50	Chipper	3.00	or Spur Gears with any Prime Mover	1.75
FOOD INDUSTRY	Merchant Mills	Refer to factory	Converting Machine	1.50	TEXTILE INDUSTRY	
Beet Slicer	Mill Tables		Couch	1.75	Batcher	1.25
Bottling, Can Filling Machine	Hot Bed or Transfer non-reversing	2.00	Cutter, Felt Whipper	2.00	Calender, Card Machine	1.50
Cereal Cooker	Roughing Breakdown Mills	4.00	Cylinder, Dryer	1.75	Cloth Finishing Machine	1.50
Dough Mixer, Meat Grinder	Runout, non-reversing, non-plugging	2.50	Felt Strtcher	1.25	Dry Can, Loom	1.50
LUMBER	Runuot, reversing	4.00	Fourdrinier	1.75	Dyeing Machinery	1.25
Band Resaw	Reel Drives	1.75	Jordan	2.00	Knitting Machine	Refer to factory
Circular Resaw, Cut off	Rod Mills	Refer to factory	Log Haul	2.00	Mangle, Napper, Soaper	1.25
Edger, Head Rig, Hog	Screwdown	1.50	Line Shaft	1.50	Spinner, Tenter Frame, Winder	1.50
Grang Saw	Seamless Tube Mills		Press	2.00		

- For motor driven reducers with resilient high speed and low speed shaft coupling, refer to Table II A. For motors with brakes, select the coupling based on the higher of the two torque ratings.
- * For balanced opposed design, divide number of cylinders by two and use above table for reciprocating compressors.

Selection of the coupling using the nominal torque (tn)

Please use the following formula:

$$tn: 9460 \times Kw \times fs \times rpm$$

Please look in Table III for the model which the nominal torque is the same or higher than the one which was originally calculated, and verify the diameter between the shafts depending on the max and minimum. (see table III - page 4)

With two Normal Hubs (drawing 1)

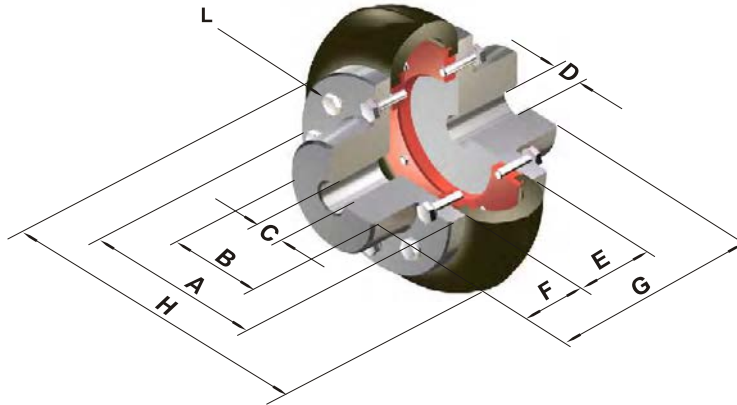

- A - Ø Flange of the Hub
- B - Ø Neck of the Hub
- C - Ø Máx. bore
- D - Ø Min. bore
- E - With of the Flexible Element
- F - Length of the Hub
- G - Length of the Flexible Coupling
- H - Ø Flexible Element
- L - Screw

Table III

NORMAL HUB													Metric Hex Cap Screws	
MODEL	Nominal Torque Nm	Torsion (°)	weight ⁽¹⁾ (Kg.)	Gd2 (Kg m2)	A	B	C Max	D Min	E	F	G	H	N.	Dimension mm
A-20	38	2°	1.05	0.0017	74	36	20	10	30	25	80	95	12	6 x 1 x 20
A-25	56	5°	1.09	0.0018	74	36	23	10	30	25	80	95	12	6 x 1 x 20
A-30	82	2°	2.40	0.0094	96	49	30	10	40	35	110	127	16	8 x 1,25 x 25
A-35	113	4°	2.65	0.0098	96	49	32	10	40	35	110	127	16	8 x 1,25 x 25
A-45	200	3°	5.00	0.0382	127	70	40	15	50	45	140	167	20	8 x 1,25 x 25
A-50	420	6°	5.32	0.0402	127	70	46	15	50	45	140	167	20	8 x 1,25 x 25
A-60	620	5°	12.50	0.1065	169	100	55	25	65	60	185	224	24	10 x 1,50 x 35
A-70	1170	9°	13.30	0.1593	169	100	65	25	65	60	185	224	24	10 x 1,50 x 35
A-80	1550	5°	24.90	0.594	218	116	75	30	90	80	250	302	20	12 x 1,75 x 45
A-90	2170	6°	26.00	0.639	218	116	85	30	90	80	250	302	20	12 x 1,75 x 45
A-95	2380	4°	34.90	0.912	235	138	90	40	90	80	250	330	24	12 x 1,75 x 45
A-105	3130	8°	44.00	0.982	235	138	100	40	90	80	250	330	24	12 x 1,75 x 45
A-120/120	4940	5°	86.00	3.80	297	195	120	45	120	130	380	403	20	16 x 2 x 60
A-140/140	8500	9°	94.00	3.82	297	195	140	45	120	130	380	403	20	16 x 2 x 60
A-155/155	9750	6°	126.00	5.76	350	220	155	50	140	150	440	470	14	16 x 2 x 60
A-165/165	12200	10°	135.00	5.85	350	220	165	50	140	150	440	470	14	16 x 2 x 60
A-170/70			170.20	12.22		150	70	30		80	345			
A-170/130	14630	7°	211.80	13.75	436	236	130	70	185	130	445	550	24	20 x 2,50 x 75
A-170/170			242.80	17.65		276	170	120		180	545			
A-200/90			192.60	13.30		186	90	40		100	385			
A-200/140	25190	11°	202.40	13.75	436	200	140	70	185	130	445	550	24	20 x 2,50 x 75
A-200/200			276.80	19.20		276	200	120		180	545			
A-240/150			364.70	51.50		225	150	100		160	556			
A-240/200	43060	4°	447.40	55.35	535	290	200	100	236	180	596	740		
A-240/240			633.60	84.50		390	240	100		275	786			
A-300/150			370.00	50.70		225	150	110		160	556			
A-300/200	86120		450.00	54.50		290	200	100		200	636			
A-300/250		10°	640.00	69.40	535	350	250	100	236	275	786	740		
A-300/300			695.00	83.70		390	300	100		275	786			
A-350/200			1049.00	453.20		290	200	120		200	735			
A-350/250	118750	6°	1211.00	466.40	820	350	250	120	335	275	885	1130		
A-350/350			2237.00	691.00		600	350	120		375	1085			
A-400/250	168750	10°	1219.00	459.20	820	350	250	120	335	275	885	1130		
A-400/400			2245.00	697.00		600	400	120		375	1085			

With one Normal hub and one integral hub (design 2)

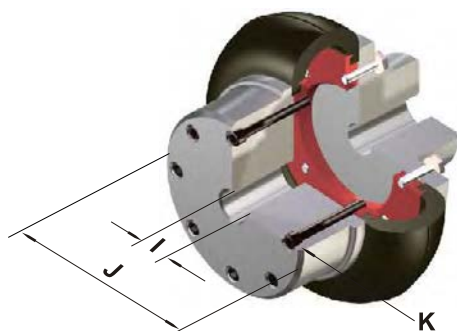

- I - Ø Máx. bore
- J - Ø Neck of the Hub
- K - Screw

Table IV

INTEGRAL HUB			Metric Socket Head Cap Screws		INTEGRAL HUB			Metric Socket Head Cap Screws	
Size	I Max	J	N. (1)	Dimension mm	Size	I Max	J	N. (1)	Dimension mm
A-20	30	66	6	6 x 1 x 30	A-120	170	*	10	16 x 2 x 150
A-25	30	66	6	6 x 1 x 30	A-140	170	*	10	16 x 2 x 150
A-30	44	86	8	8 x 1,25 x 40	A-155	200	*	14	16 x 2 x 165
A-35	44	86	8	8 x 1,25 x 40	A-165	200	*	14	16 x 2 x 165
A-45	60	110	10	8 x 1,25 x 50	A-170	250	*	12	20 x 2,5 x 200
A-50	60	110	10	8 x 1,25 x 50	A-200	250	*	12	20 x 2,5 x 200
A-60	90	150	12	10 x 1,50 x 65	A-240	*	*	30	
A-70	90	150	12	10 x 1,50 x 65	A-300	*	*	30	
A-80	100	180	10	12 x 1,75 x 95	A-350	*	*	30	
A-90	100	180	10	12 x 1,75 x 95	A-400	*	*	30	
A-95	125	198	12	12 x 1,75 x 95					
A-105	125	198	12	12 x 1,75 x 95					

Integral Hubs can be used when the shaft diameter is greater than the ones listed in Table III.

The Assembly can be used with one or two integral hubs according to the applications needs.

TYPE OF ASSEMBLY

With spacer (ES)

All the different coupling version can be outfitted with a spacer, which facilitates the disassembling, which is common in pump applications (Back pull-out).

For this request, please indicate the distances between the shaft points "L".

MODEL	ES 75	ES 100	ES 140	ES 180
A-20/25	*	*	*	
A-30/35		*	*	*
A-45/50		*	*	*
MODEL	ES 140	ES 180	ES 215	ES 250
A-60/70	*	*	*	
A-80/90		*	*	*
A-95/105		*	*	*

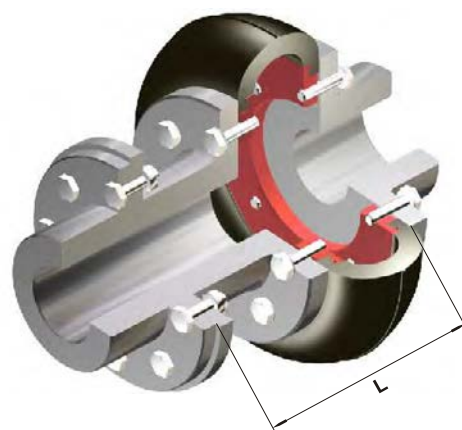

High speeds (CE)

For applications where the speeds fall outside of the parameters in the table, the shafts must be dynamically balanced and aligned, and used with fitted hubs.

When making this request, please indicate the rotating speed (RPM)

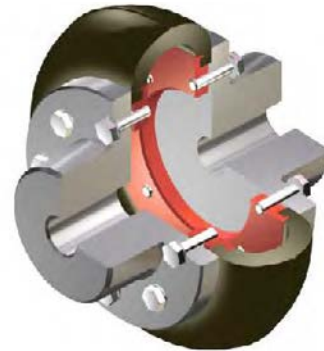

Floating Shafts (EF)

The floating shaft coupling used with the shaft tip guide allows for a higher angular and axial movement.

Specially designed to be used in cooling tower applications.

For this request, please indicate the distances between shaft points.

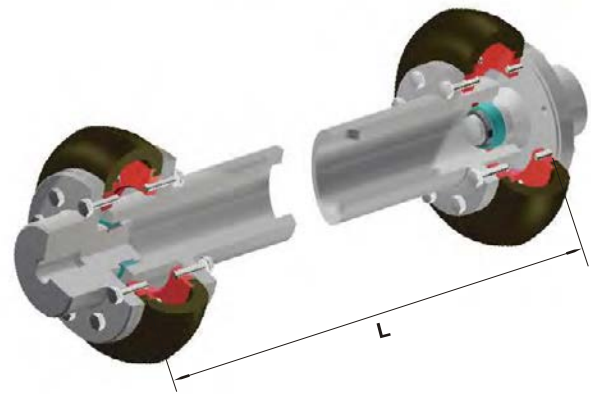

Axial Hub (CX)

This model has been developed for applications that do not allow for axial displacement due to their construction characteristics. Use indicated hubs for machines with sliding shafts.

When making the request, indicate the maximum displacement.

MODEL	Ø Max.	Ø Min.	MODEL	Ø Max.	Ø Min.
A-20/25	21	15	A-95/105	73	40
A-30/35	29	15	A-120/140	102	50
A-45/50	42	15	A-155/165	140	60
A-60/70	60	25	A-170/200	180	70
A-80/90	64	30			

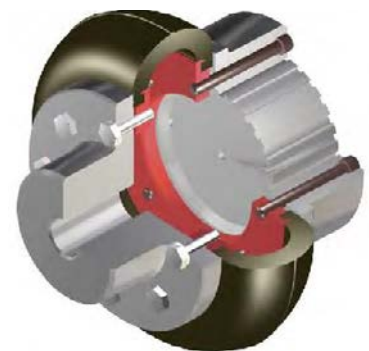

With Drum Brakes (APF)

Combined with drum brakes, and applies to mechanical, electromagnetic, and Air Brakes.

It is recommended only with standard drums which have an outside diameters of 6", 8", 10", 12", 14", and 16".

If your application requires other diameters, please consult with our engineering department.



Special Versions

Assembly on Fly Wheels - Mounting Plate (CF)

For applications where it is convenient to assemble the coupling onto the fly wheel of an engine, when the mounting space is limited, it is recommended that you use a Mounting Plate model.

Indicate flange size when ordering.

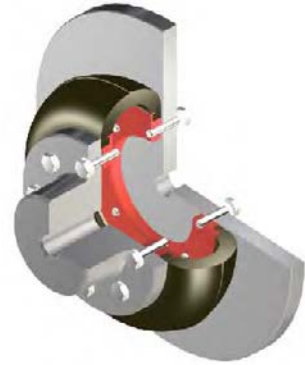

Assembly of Fly Wheels - Extended Mounting Plate (CC)

For applications where it is convenient to assemble the coupling onto the fly wheel of an engine, when the mounting space is not limited, it is recommended that you use an Extended Mounting Plate.

Consult with Gummi Engineering Department for different size models.

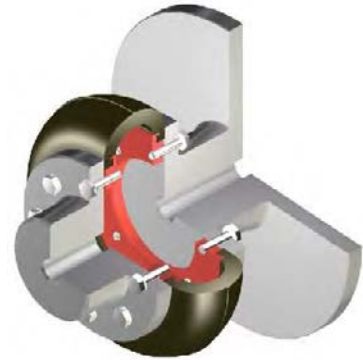

Torque Limiters (LT)

Designed to protect the transmission on Torque overloads. The LT type coupling allows slippage, avoiding any adverse effect of the torque overload on the transmission.

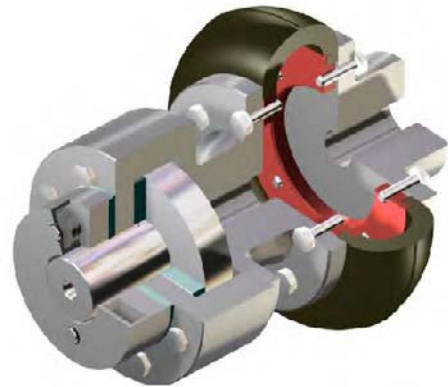

Security Ties (BS)

Used in applications when the transmission must continue functioning, regardless of overloads. The Security Ties limit the possibility of failure with the Flexible Coupling.

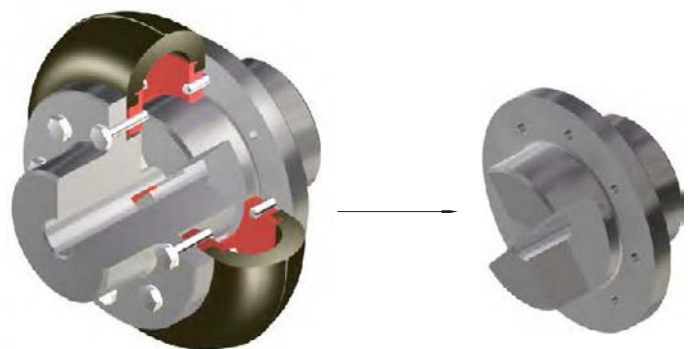

For Disc Brakes (DF)

Designed to be used with a disc or ventilated brake, or with air / hydraulic systems.

For the disc diameters, consult Gummi Engineering Department.



Inverted Hub (CIN)

For installations where a standard coupling configuration would be difficult to mount, due to reduced space between shafts. The type CIN design allows the coupling to be mounted with one inverted hub greatly reducing the coupling overall width.

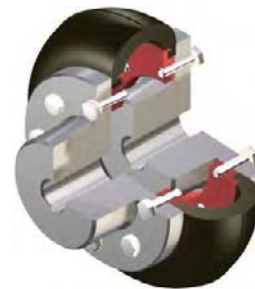

Assembly Instructions

The Values "A" and "R" are the maximum tolerances allowed.

MODEL	E (mm)	tol (mm)	ANGULAR (°)	RADIAL (mm)	TORQUE (Nm)	
					Tightening cross	circular
A20 / 25	30	0.5	0.5	0.25	5	5
A30 / 35	40	0.5	1	0.4	7.5	10
A45 / 50	50	1	1.5	0.5	10	20
A60 / 70	65	1	1	0.8	20	30
A80 / 90	90	2	1.5	1	50	60
A95 / 105	90	2	1.5	1	50	60
A120 / 140	120	4	2	2	60	70
A155 / 165	140	4	2	2	60	70
A170 / 200	185	4	3	3	100	150
A240 / 300	236	5	4	3	150	220
A350 / 400	335	5	4	3	180	250

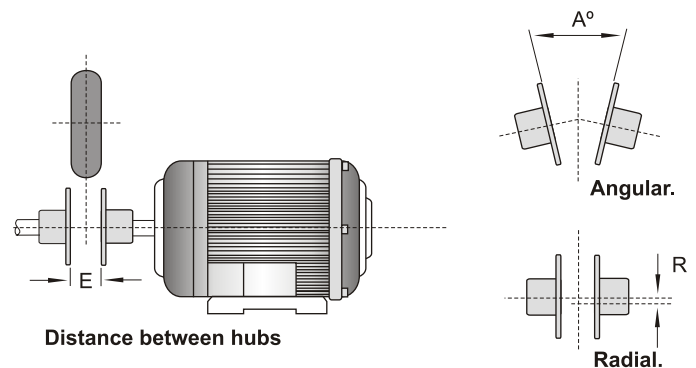

In the initial assembly, the hubs must be aligned and left with a gap between both hubs equal to the distance "E" indicated in the table.

Example to assembly the coupling

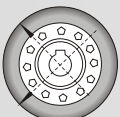

- First adjustment in the shape of the cross.

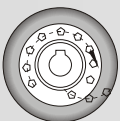

- Second adjustment in circular motion.

For a precise adjustment, use a torque wrench and tighten according to the torque values shown in the table.

For the adjustment of taper lock hubs and or flywheels, use only Dynamometer.

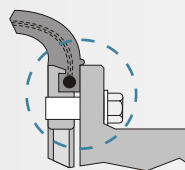

Correct Adjustment

We recommend that you check and re tighten the coupling after the first 24 Hours of operation after installation.

Incorrect Adjustment

Over tightening can cause premature failure in the flexible coupling.

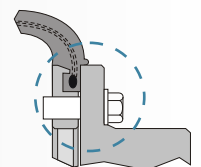

Hazardous Environments (BE)

The elastomeric compound used within Gummi's rubber elements generally provides good resistance to chemical products and aggressive agents. In the cases where the coupling will be continuously operating in Hazardous environments, the application of a special coating on to the rubber element is recommended. When ordering, please indicate what agents and conditions will be encountered and on what frequency.

Steam	●●
Acid	●●
Oil	●
Ethanol Glycerin	●●●
Outdoors - extreme heat or cold	●●
	● Low ●● Medium ●●● High



Due to the importance of these applications, and faced with the challenge to satisfy the request of these customers, Gummi continues to develop new and exclusive technologies that apply to High Torque applications.



As with our standard line of flexible couplings, Gummi continues to develop our newest coupling models and compounds that increase the ability to transmit power by 25%.

Gummi, Total Quality.



In the last few years, Gummi has become a consultant to various companies that invest in preventative maintenance and technical development in order to optimize their cost in high performance applications.



As a result, we have designed couplings with the following performance characteristics;

- High Capacity to transmit torque
- Compact Designs*
- Protection to increase working life of primary and secondary machine components and parts

* in the same side of flexible coupling, we get until 5 times the nominal torque.





SAUVE S.A.

Gdor. Ugarte 2682 (C.P. 1636)
Olivos -Buenos Aires - Argentina

Sales Department

Phone: (+54 11) 4760-7938
intl.sales@gummiargentina.com

www.gummiargentina.com

